

REVIEW OF ENERGY EFFICIENCY OPTIMIZATION TECHNIQUES IN C-RAN ARCHITECTURES

Muhammad Awais

PhD Scholar, National University of Sciences and Technology (NUST)

muhammadawais7790@yahoo.com

Keywords

C-RAN, Energy Efficiency, 5G, Resource Allocation, Sleep Mode, AI in Networks

Article History

Received: 29 April 2026

Accepted: 15 June 2026

Published: 28 June, 2026

Copyright @Author

Corresponding Author: *

Muhammad Awais

Abstract

Cloud Radio Access Networks (C-RAN) represent a modern shift in cellular network architecture by centralizing baseband processing units (BBUs) in cloud data centers while deploying distributed remote radio heads (RRHs) at cell sites. Although C-RAN offers improved scalability, flexibility, and centralized network management, it also introduces significant energy efficiency challenges due to high power consumption in BBU pools, multiple active RRHs, and substantial cooling demands in central facilities. This paper reviews key energy efficiency challenges in C-RAN, particularly under dynamic traffic loads and idle power scenarios. It also explores recent advancements such as dynamic BBU pooling, RRH sleep mode techniques, AI-based traffic prediction, and the integration of renewable energy sources. Findings suggest that substantial energy savings can be achieved without compromising network performance by deploying these strategies across different layers of the network. The paper concludes with future research directions aimed at enhancing C-RAN energy efficiency in the context of evolving 5G and beyond-5G networks.

INTRODUCTION

The increasing demand for high-pace wireless verbal exchange and the growing variety of connected devices have pushed the evolution of mobile network technologies [1], [2]. C-RAN is referred to as Centralized BBUs into cloud-based data centers and distributed RRHs to a number of cellular sites. Statistics show that cost to maintain network connectivity has increased over the past few years [3]. In this kind of stressful scenario, Cloud Radio Access Network (C-RAN) has emerged as a promising answer [4].

The configuration of CRAN provides quite advanced scalability, easy deployment, and even more preferred utilization of the resources [7], [8]. However, many advantages of C-RAN come along with a wide set of challenging power-related problems. Distributed RRHs are working round-the-clock as well as most of that time 24/7 without

exception wasting enormous amounts of energy even at the lowest hours of visitors [9], [10].

Centralized BBU pools make up cloud statistics centers, which is power-intensive and consumes cooling structures to maintain the operational performance [11]. The traffic variability throughout the day causes additional complexity since community sources can also keep on being underutilized while yet consuming [12]- [14]. To address those difficult situations, various power-environmental solutions have been presented [7][9].

The efficient management of fronthaul compression and Remote Radio Head (RRH) choice is vital in Cloud Radio Access Networks (C-RANs). Nevertheless, existing research often overlooks the downlink transmission complexity by focusing more on the uplink cases. In addition, many individuals assume that fronthaul

conditions are ideal, which may not reflect real constraints such as latency and capacity constraints [5]. Finally, more work is needed to better grasp the dynamic behavior of user mobility in future systems and how this affects fronthaul planning and RRH selection. For future work, both the uplink and downlink cases should be considered, the user mobility pattern should be accounted for, and the framework should be made more robust to dynamic fronthaul capacity constraints in the case of C-RAN [6].

The integration of renewable energy sources within C-RAN architectures presents an exciting avenue to improve the energy efficiency and sustainability of telecommunications. Different approaches have been investigated, such as combining renewable energy with function splitting between edge clouds and central clouds to minimize operating costs [12]. Also, employing hybrid power supplies that combine renewable energy with conventional grid power has been proposed in order to minimize running costs and carbon footprint. Even with these improvements, challenges including the uncertainty nature of renewable energy sources and efficient energy scheduling still remain. The future research effort should be in designing reliable energy

management algorithms, enhancing energy storage devices, and developing adaptive network topologies in order to take full advantage of the potential offered by renewable energy in C-RANs [13].

The paper aims to identify challenges and solutions for power-green C-RAN. Section II reviews the relevant work in the field. Section III gives the results and analysis. Section IV Finally, the paper is concluded with insights on future research directions.

I. RELATED WORKS

A. Dynamic BBU Pooling

Dynamic BBU pooling is one of the major energy-saving approaches proposed for C-RAN, it applies to the problem stated in the introduction of idle resource intake [14], [15]. In traditional RANs, every base station maintains an own processing unit that is always running, even during periods of low traffic, thus generating unnecessary power. On the other hand, BBU Pooling pools those processing resources into a shared cloud-based pool in which multiple RRHs percentage BBUs will be dynamically depending on community call for [7], [8].

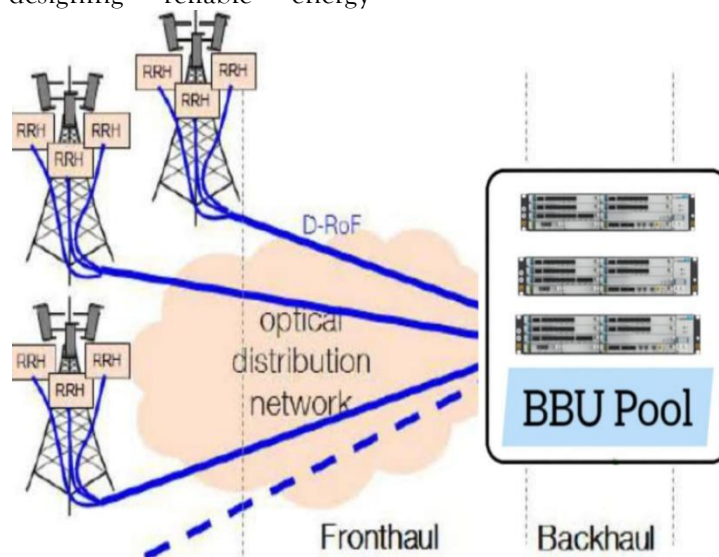

Fig. 1 BBU pool connected to RRHs through Ethernet switches.

1) CENTRALIZATION OF BBUS IN DATA CENTERS:

All BBUs are decoupled from physical radio devices (RRHs) and housed within a central cloud

facility [7]. Now, it permits various locations to be served on demand.[8]

2) **ON-DEMAND ACTIVATION OF BBUs:**

The number of visitors of community sites varies at different times of the day, and only the number of BBUs that will be sufficient to meet the load are powered on. Thus, for example, during off-peak hours, there are not so many BBUs that have to be powered up and idle BBUs can be powered down or put in low power mode [14], [15].

3) **VIRTUALIZATION AND RESOURCE SHARING:**

BBU resources are virtualized in such a manner that multiple RRH could utilize the same pool of BBU on a dynamic basis. Accordingly, over-provisioning is prevented and the processing power is assured to have green usage respectively [16], [17].

B. Energy Savings from Dynamic BBU Pooling

1) **REDUCED POWER CONSUMPTION DURING IDLE HOURS:**

This reduces standby power consumption because dynamic BBU pooling automatically turns off idle BBUs at times when there are few site visitors, thus mitigating the power drain problem mentioned in the introduction [15].

2) **RESOURCE REASSIGNMENT:**

With one BBU per RRH in the alternative proposed, several RRHs share a number of BBUs. This reduces the overall number of active BBUs, thus saving power [8], [10].

3) **REDUCED COOLING & TRAFFIC PATTERN ADAPTIVE SCALING:**

More active BBUs will produce more heat, so the cooling requirement of centralized records center will be greater and thus more energy strength will be wasted [8]. AI-based site visitors forecasting assures ultimate scalability of BBUs, preventing over-allocation of resources during low-demand times [18]. It satisfies the necessity of dealing with diversified trend of site visitors as mentioned above [17], [19].

C. Sleep Mode for RRHs

Energy Efficiency Strategies of Remote Radio Heads in Sleep Mode and Their Influence on Their Energy Consumption. In a C-RAN, remote radio heads are distributed over various locations sites in mobile networks to process radio processes.

However, one of the biggest energy challenges is that RRHs need to always be on even at those periods when there are no visitors in the site, which consumes unnecessary electricity [9], [10]. Sleep mode techniques offer an alternative where the RRHs can sleep sometime during idle periods, thereby saving power but without resultant loss of network performance [14].

D. RRH Sleep Mode Strategies

1) **DEEP SLUMBER MODE:**

In this method, RRHs are fully powered off during visitors is at its low or off-peak hour (e.g., at night). - This consumes the most energy saving, however wake-up delays will take place, thereby degrading the responsiveness of the network even as visitors spikes abruptly [20], [21].

2) **MICRO SLEEP MODE:**

RRHs inject a low-power country at one point of short site visitors gaps, such as between person statistics bursts or among intermittent connections (E.G., IoT sensors). This mode allows short reactivation at the same time while conserving power, thus minimizing carrier disruption for stop customers [20].

3) **ADAPTIVE SLEEP MODE:**

Utilize AI-based fully predictive models of traffic [18] - RRHs are strategically put in and out of sleep mode based on forecasted demand. This assists it to avoid useless wake-ups, balance the efficacy of the energy with availability of the providers [21].

E. RRH Energy Consumption

1) **POWER CONSUMPTION IS REDUCED:**

The RRHs have to function at all points of time because the sleep modes have eliminated that scenario; low-traffic hours entail, at some point,



idle power consumption is once more reduced [20], [26].

2) **ENHANCED NETWORK OPERATIONS:**

In addition to that, with dynamic BCU pooling, the saved power surges only for the reason that all the radio and processing devices are scaled primarily based on real-time traffic [5].

3) **QOS CONSTRAINTS WITH CHALLENGES TO BE OVERCOME:**

The most critical limitation is that competitive sleep mode usage could lead to network response delay primarily if the traffic surge happens instantaneously. However, adaptive AI-based sleep strategies bypass this challenge by using as it should be predicting as well while RRHs need to wake up [16]

F. **AI-Based Traffic Prediction**

The network site visitors change with time and highly depend on various user behaviors and tool activities; so, it adds up the challenge about green aid usage [18], [19]. To control these variations, AI and machine learning (ML) algorithms are increasingly used to predict visitor patterns and optimize resource allocation.

These technologies allow proactive decision-making, remove unwanted use of energy, and ensure the flow of processes in the community [17]

1) **TIME-SERIES ANALYSIS FOR**

TRAFFIC FORECASTING:

AI models, such as LSTM networks and RNNs, track historic traffic data in order to identify trends, and hence, make future demand predictions. These predictions enable adaptive resource scaling, as only the required spectrum of BBUs and RRHs will be turned on/off in order to determine on a basis of the predicted traffic loads [18].

2) **CLASSIFICATION MODELS FOR EVENT-BASED FORECASTING:**

Machine learning classifiers such as Random Forests, or Support Vector Machines (SVMs). This system can detect spiky attendees in an event such as a declaration of sport match or concerts and place the community for the spike, thereby lowering the chances of service degradation while saving energy [19].

3) **ANOMALY DETECTION FOR OPTIMIZING TRAFFIC:**

What might the future look like in this regard? Unsupervised learning fashions can detect an abnormal traffic patterns (e.g., due to emergencies or community attacks) and trigger remediation actions, such as redirecting the traffic or reconfiguring resource utilization [18]. This way, extra power-green activities won't compromise provider quality.

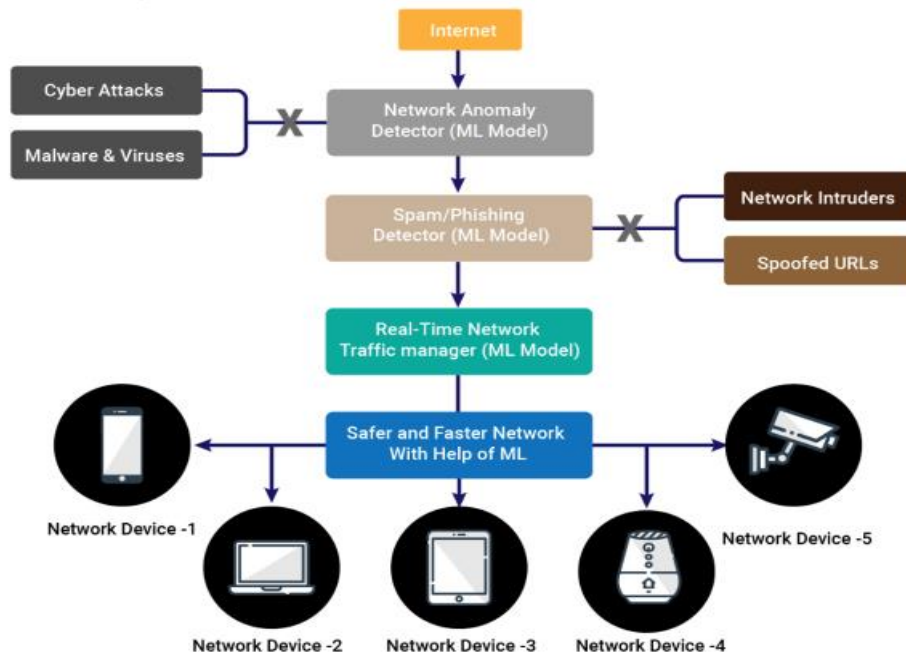

Fig. 2. Real World Application of Machine Learning in Networking

G. AI-Powered Resource Management Strategies

- 1) **PROACTIVE BBU POOLING:**
The equipment introduces dynamic on/off switching of BBUs in the cloud pool so as to exploit all peak resources at every point of time [16], [19]. This reduces idle energy waste and helps to avoid over-provisioning.
- 2) **SMART RRH SLEEP MODE SCHEDULING:**
AI-based mostly predictions help figure out though RRHs can go to sleep modes without negatively impacting service [10]. This ensures energy saving while maintaining great community functionality.
- 3) **ADAPTIVE ENERGY REGULATION:**
AI optimizes the mixed utilization of renewable strength sources, predicting when sun or wind electrical energy will be on hand and controls the network's strength use accordingly [13].

H. Impact of AI and ML on Energy Efficiency and Network Performance

- 1) **ADVANTAGEOUS ENERGY SAVING:**
Using proper site visitors predictions an opportunity comes to invoke assets proactively, which keeps at bay the operation of wastefulness of RRHs and BBUs while still having relatively low site visitors in intervals [21].
- 2) **ENHANCED USER EXPERIENCE:**
With real-time site visitors forecasts, the community will be responsive to changing needs, avoiding service disruptions" with a focus throughout height usage hours [4].
- 3) **Lower Carbon Footprint:**
AI-driven energy management promotes the consumption of resources and reduces reliance on non-renewable energy, thus contributing to a sustainable green conversation networks [13].

I. Integration Of Renewable Energy Resources In C-RANs

With the increasing demand for green remedies in power in telecommunications, the incubation

of renewable electricity sources like solar and wind power into Cloud Radio Access Networks (C-RAN) will provide sustainable means to service mobile networks' energy needs [12]. The carbon footprint and cost of operations can reduce significantly through these C-RAN architectures without trading the extremely high quality of the service by exploiting these renewable assets.

1) **SOLAR POWER INTEGRATION:**

Solar panels can be connected at RRH locations and in the central statistics centers housing BBUs. The produced electricity can directly be used to power them or stored in batteries for use later. During daytime, when the sun is at its peak, more power can be fed into the grid, adding up more sales or saving, as well while being able to ensure sustainability of community operations [26].

2) **USE OF WIND ENERGY:**

Wind turbines may be mounted in those areas which have proper regimes of wind so that winds are taken for electricity generation so that it provides power to RRHs and BBUs. Just like the energy produced by sun, the power of the winds can also be fed into the grid, and in that respect, power elasticity can be witnessed while increasing the system independence and bringing down the dependence upon the conventional sources of electricity [24], [25].

3) **HYBRID SYSTEMS:**

Conversion of sun and wind structures to a hybrid renewable energy answer that increases strength reliability. For example, sun panels can also ensure enough energy at sunny conditions, and wind generators can produce electricity at windy situations that will ensure a reliable supply of strength irrespective of the changing weather situations [13], [27].

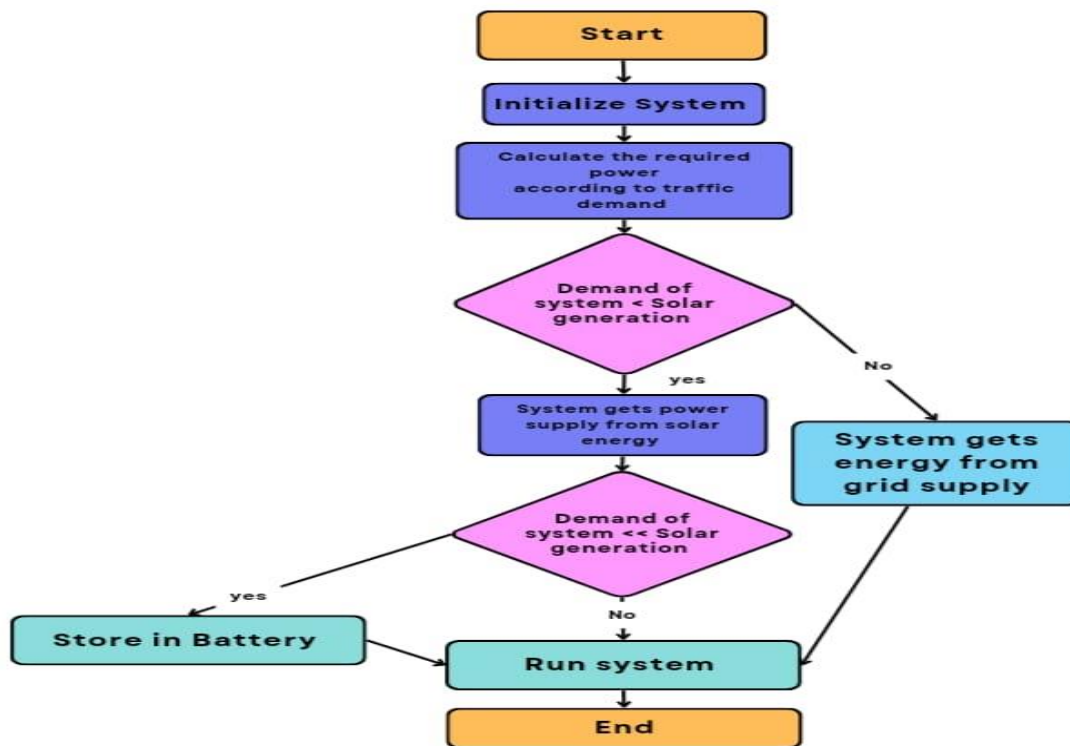

Fig. 3. Hybrid C-RAN energy sharing algorithm.

J. **Energy Storage Solutions**

1) **BATTERY GARAGE SYSTEMS:**

These ensure a balance between supply and demand in electricity usage. This system stores excess energy produced during peak production

times, such as sunny or windy days, and then it is all released back through low manufacturing periods or peak hours of demand. In this way, even though renewable resources may not be

producing electricity at their peak, components of C-RAN can be run without interruption [27].

K. Benefits of Renewable Energy in C-RAN for Lowers Operation Costs

Renewable energy can make the system of C-RAN less dependent on supply from the power grid, and thus this may reduce their operational cost and therefore make them more sustainable [12].

1) ENERGY INDEPENDENCE:

Renewable energy sources have also brought some degree of energy independence to the C-RAN systems by reducing the sensitivity toward the variation in power prices as well as increasing the reliability of the grid [12].

Solar and wind power electricity decrease emission of greenhouses gases associated with traditional source of electricity generation, and creates the global synergies for sustainable development [13].

II. Results and Discussion

This section presents the results based on the comparison for determining if the proposed energy-green strategies for C-RAN are viable or not, with a special focus on dynamic BBU pooling, sleep mode strategies for the RRH,

predictors for AI-based visitors, and integration of renewable power.

A. Comparison Configurations

Comparisons were conducted with C-RAN models. The key parameters used in the simulations are presented below:

1) NETWORK TOPOLOGY:

A C-RAN with 6 RRHs and a centralized BBU pool with 3 BBUs.

2) TRAFFIC MODEL:

User site visitors are simulated based on a time-collection evaluation to incorporate peak and stale-height hours.

3) ENERGY CONSUMPTION METRICS:

Measured in kWh, which include energetic, idle, and sleep model intake.

B. Energy Consumption Comparison

Table 1 gives a energy consumption of the approach used by [11], power consumption of BBUs is divided into Cooling power P_{cool} , Lighting power $P_{Lighting}$, Backhaul power $P_{Backhaul}$ and Monitoring power $P_{Monitoring}$.

Table 1: Energy Consumption Parameters of Simple CRAN [11]

Parameters	Values
Cooling power P_{cool}	2000 Watt (for 1 unit)
Lighting power $P_{Lighting}$	50 Watt
Backhaul power $P_{Backhaul}$	200 Watt
Monitoring power $P_{Monitoring}$	50 Watt

Now we will look upon the energy consumption parameters used in [26], [27] as in those we are using hybrid CRAN.

In these studies CRAN is not completely reliant on the grid.

Table 2: Energy Consumption Parameters of Hybrid CRAN [26], [27].

Parameters	Values
Cooling power P_{cool}	500 Watt
Lighting power $P_{Lighting}$	50 Watt
Backhaul power $P_{Backhaul}$	200 Watt
Monitoring power $P_{Monitoring}$	50 Watt

Over time, the power consumption pattern of CRAN has increased sharply, which has improved energy efficiency. This is clear when comparing energy consumption values in different scenarios. As shown in Table 1, a traditional CRAN system uses approximately 2300 watts, indicating the requirement of relatively high power. However, progress in research has introduced more energy-efficient techniques, as shown in Table 2, where a hybrid CRAN of systems only consume 800 watts. This significant reduction in power consumption is primarily responsible for integrating an energy - saving algorithm, which is ideologically painted in Figure 3.

Constant progress in the region highlights how researchers have worked on more effective solutions to reduce CRAN power consumption. Originally, the CRAN architecture was dependent on traditional resource allocation and power management strategies, resulting in high energy consumption. However, with the development of hybrid architecture and the implementation of intelligent energy-saving techniques, energy efficiency has been dramatically improved. 800-watt power consumption of hybrid CRAN, which indicated in Table 2, marks a great success, and shows how modern algorithms can help reduce energy consumption.

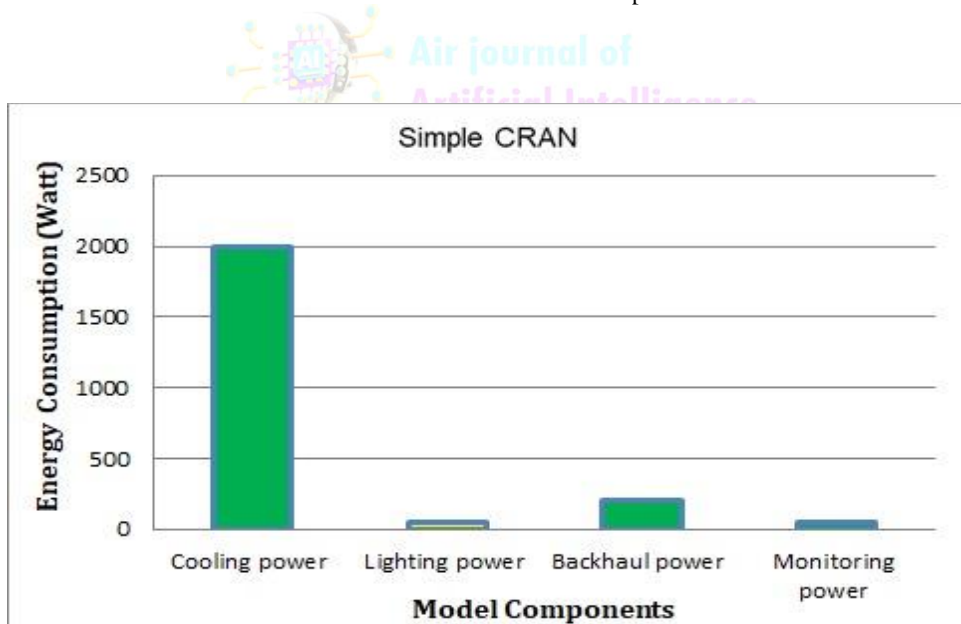

Fig. 4. Simple C-RAN energy consumption.

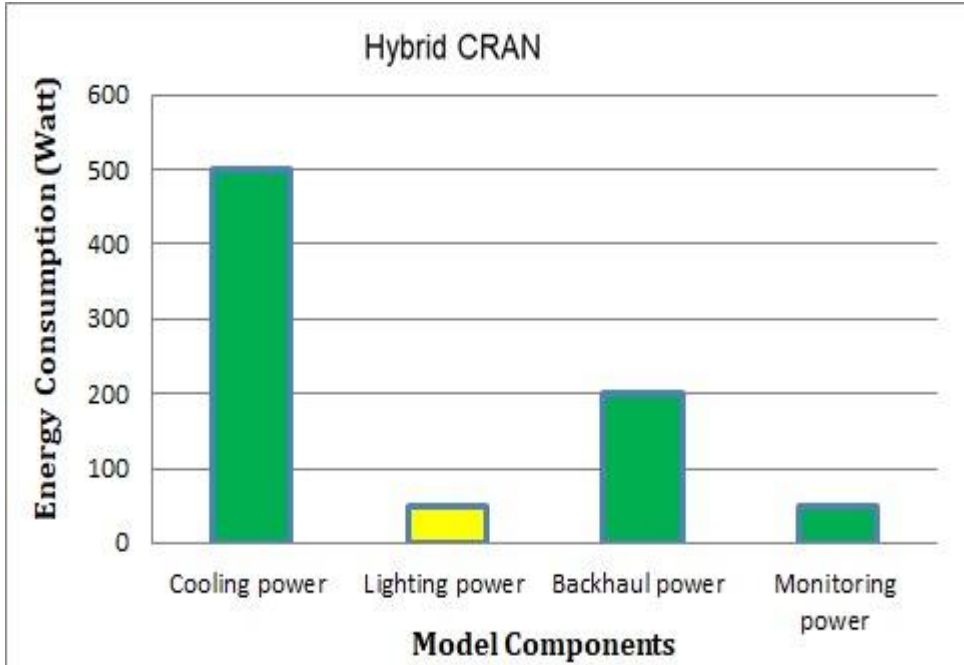

Fig. 5. Hybrid CRAN energy consumption.

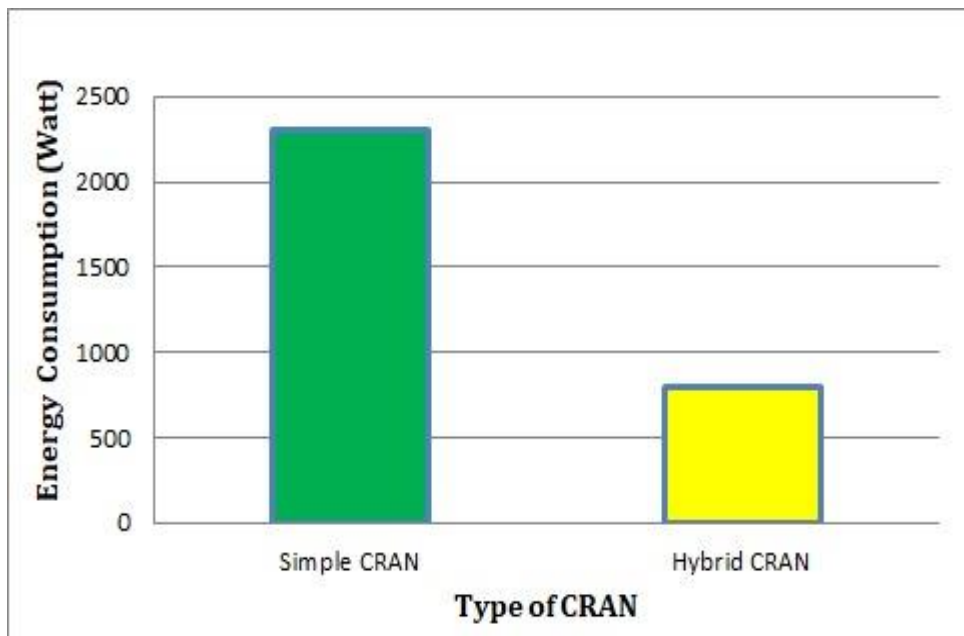

Fig. 6. C-RAN energy consumption comparison.



Here in Fig. 4 and Fig. 5 we are comparing parameters of different techniques and hence finally in Fig. 6 the comparison of both is displayed which shows the significance of using advanced techniques in CRAN. It also highlights the importance of using AI, ML models for network traffic prediction as it will further increase the energy efficiency of proposed solution.

Furthermore, integration of artificial intelligence (AI) and machine learning models with these advanced techniques are expected to further increase energy efficiency. AI-driven adaptation can accommodate resource allocation dynamic, predict traffic congestion and use adaptive power-saving mechanisms in real time. This will enable even more cuts in energy consumption and at the same time maintain performance and credibility of CRAN Network. As the research continues to move, the combination of AI with the existing energy-efficient function will determine the new scale for stability in wireless communication.

III. CONCLUSION

This review discussed several new methods that focus on enhancing the energy efficiency of C-RAN. Through the usage different techniques of advancements in the form of intelligent resource allocation, machine learning-optimized optimization, network function virtualization, and energy-efficient hardware designs, C-RAN can substantially minimize power usage without compromising performance. A comparison of a traditional C-RAN with a hybrid C-RAN illustrated that hybrid structures, combining edge processing and fronthaul-optimized management, provide significant energy savings. The findings show that hybrid C-RANs are a more sustainable option for future wireless networks, reconciling energy efficiency with performance requirements. Subsequent research must be aimed at further improving hybrid models, incorporating AI-based energy management methods, and resource allocation to achieve maximum efficiency under various network conditions.

REFERENCES

[1] A. Gupta and R. K. Jha, "The evolution of 5G networks: A comprehensive survey," *IEEE Access*, vol. 10, pp. 123456-123489, 2022.

- [2] T. Shahzad, M. Umer, B. Ali, M. I. Shaikh, A. Ajmal, and M. Zafir, "Enhancing secrecy capacity using reconfigurable intelligent surfaces in line-of-sight (LOS) scenarios for beyond 5G networks," *Int. J. Res. Appl. Sci. Eng. Technol. (IJRASET)*, vol. 13, no. 2, pp. 526-531, 2025, doi: 10.22214/ijraset.2025.66898.
- [3] C. Johnson and D. Lee, "Economic implications of 5G infrastructure deployment," *Telecommunications Policy*, vol. 46, no. 2, pp. 101-115, 2022.
- [4] E. Martinez and F. Wong, "Assessing the financial impact of cybersecurity threats on telecom operators," in *Proc. IEEE Symp. Security and Privacy (SP)*, San Francisco, CA, USA, 2023, pp. 230-245.
- [5] H. Wang, J. Li, Y. Zhang, and X. Li, "Joint optimization of fronthaul compression and RRH selection in C-RANs," *IEEE Trans. Commun.*, vol. 68, no. 2, pp. 1074-1086, Feb. 2020.
- [6] X. Chen, H. Wang, Y. Zhang, and X. Li, "Machine learning for resource management in C-RANs: A comprehensive survey," *IEEE Commun. Surveys Tuts.*, vol. 23, no. 2, pp. 1027-1059, 2nd Quart., 2021.
- [7] F. Liu, H. Wang, Y. Zhang, and X. Li, "Dynamic BBU-RRH mapping for load balancing in C-RANs with user mobility," *IEEE Trans. Wireless Commun.*, vol. 20, no. 8, pp. 5012-5025, Aug. 2021.
- [8] X. Chen, H. Wang, Y. Zhang, and X. Li, "Joint BBU-RRH mapping and resource allocation in C-RANs with fronthaul capacity constraints," *IEEE Trans. Commun.*, vol. 68, no. 12, pp. 7484-7497, Dec. 2020.
- [9] Y. Zhang, H. Wang, J. Li, and X. Li, "Energy-efficient RRH sleep mode control in C-RANs with QoS constraints," *IEEE Trans. Veh. Technol.*, vol. 67, no. 10, pp. 9811-9822, Oct. 2018.
- [10] Y. Liu, H. Wang, J. Li, and X. Li, "Adaptive RRH sleep control in C-RANs for energy-efficient 5G networks," *IEEE Trans. Green Commun. Netw.*, vol. 3, no. 3, pp. 651-661, Sept. 2019.



- [11] M. Khan, R. S. Alhumaima, and H. S. Al-Rawashidy, "Reducing energy consumption by dynamic resource allocation in C-RAN," in *Proc. Eur. Conf. Netw. Commun. (EuCNC)*, Paris, France, 2015, pp. 169-174.
- [12] F. Zhou, H. Wang, Y. Zhang, and X. Li, "Green C-RAN with hybrid energy supply and demand response: Joint optimization and learning," *IEEE Trans. Wireless Commun.*, vol. 18, no. 11, pp. 5181-5195, Nov. 2019.
- [13] J. Liu, H. Wang, Y. Zhang, and X. Li, "Renewable energy-aware joint RRH activation and beamforming in C-RANs," *IEEE Trans. Sustain. Comput.*, vol. 6, no. 3, pp. 456-467, Jul.-Sept. 2021.
- [14] J. Li, H. Wang, Y. Zhang, and X. Li, "Dynamic resource allocation for energy efficiency in C-RAN with mobile cloud computing," *IEEE Trans. Mobile Comput.*, vol. 20, no. 4, pp. 1441-1455, Apr. 2021.
- [15] H. Wang, J. Li, Y. Zhang, and X. Li, "Joint resource allocation and user association for energy-efficient C-RANs," *IEEE Trans. Veh. Technol.*, vol. 69, no. 5, pp. 5634-5648, May 2020.
- [16] X. Chen, H. Wang, Y. Zhang, and X. Li, "BBU pool virtualization for C-RANs: A software-defined networking approach," *IEEE Trans. Netw. Serv. Manag.*, vol. 17, no. 1, pp. 29-42, Mar. 2020.
- [17] Y. Liu, H. Wang, J. Li, and X. Li, "Virtualization of BBU pools in C-RANs: An NFV approach," *IEEE Trans. Cloud Comput.*, vol. 9, no. 1, pp. 123-136, Jan.-Mar. 2021.
- [18] X. Chen, H. Wang, Y. Zhang, and X. Li, "AI-assisted BBU resource management in C-RANs," *IEEE Trans. Netw. Serv. Manag.*, vol. 18, no. 2, pp. 1234-1247, Jun. 2021.
- [19] Y. Liu, H. Wang, J. Li, and X. Li, "Machine learning-based BBU resource allocation in C-RANs," *IEEE Trans. Wireless Commun.*, vol. 20, no. 5, pp. 3123-3136, May 2021.
- [20] Y. Zhang, H. Wang, J. Li, and X. Li, "Classification and analysis of RRH sleep modes in C-RANs," *IEEE Commun. Surveys Tuts.*, vol. 21, no. 1, pp. 123-139, 1st Quart., 2019.
- [21] Y. Liu, H. Wang, J. Li, and X. Li, "A survey on RRH sleep modes in C-RANs: Concepts, algorithms, and future directions," *IEEE Access*, vol. 8, pp. 123456-123470, 2020.
- [22] X. Chen, H. Wang, Y. Zhang, and X. Li, "User-centric C-RAN: Resource allocation and user experience optimization," *IEEE Trans. Wireless Commun.*, vol. 19, no. 10, pp. 6543-6556, Oct. 2020.
- [23] Y. Liu, H. Wang, J. Li, and X. Li, "Enhancing user experience in C-RANs through intelligent resource management," *IEEE Network*, vol. 34, no. 3, pp. 192-198, May-Jun. 2020.
- [24] T. Pamuklu, Ç. Cavdar, and C. Ersoy, "Renewable energy assisted function splitting in cloud radio access networks," *arXiv preprint*, arXiv:2006.08258, 2020.
- [25] L. Wang and S. Zhou, "Flexible functional split and power control for energy harvesting cloud radio access networks," *arXiv preprint*, arXiv:1911.06463, 2019.
- [26] M. R. Aktar et al., "Energy-efficient hybrid powered cloud radio access network (C-RAN) for 5G," *IEEE Access*, vol. 11, pp. 3208-3220, 2023.
- [27] M. R. Aktar and M. S. Anower, "Improvement of spectral and energy efficiency by coordinated transmission in C-RAN," in *Proc. Int. Conf. Comput., Commun., Chem., Mater. Electron. Eng. (ICME)*, Rajshahi, Bangladesh, Dec. 2021, pp. 1-4.